

BMW Canada Inc.

2013 Product Planning Bulletin



2014MY 2 Series Coupé

In a step forward, BMW is launching the first ever 2 Series Coupé, an evolution of the outgoing 1 Series product line. The new “2 Series” moniker was introduced as part of a global naming realignment that sees all sedans with odd number designations (1, 3, 5, 7, X1, X3, X5) and coupé’s even-number (2, 4, 6, X4, X6). The change also speaks to the maturing of the vehicle as it grows significantly in length and width resulting in significant improvements in rear legroom, trunk space and overall refinement. The new 2 Series Coupé launches **March 1, 2014** with two variants, the 228i and M235i (replacing 135i).

Dimensional Improvements:

The new 2 Series Coupé has undergone significant structural changes vs. the outgoing 1 Series Coupé. The new vehicle grows in length by an impressive 72mm, adding 21mm of rear leg room and an additional 20L of trunk space. The combination of growth to the front and rear track (41mm) and a 5mm drop in overall ride height produce an even more athletic stance. Despite all of these dimensional gains, the total curb weight doesn’t increase, thanks to more extensive use of aluminum and other lightweight materials. In addition, the 2 Series Coupé maintains a near-perfect 50:50 weight distribution.

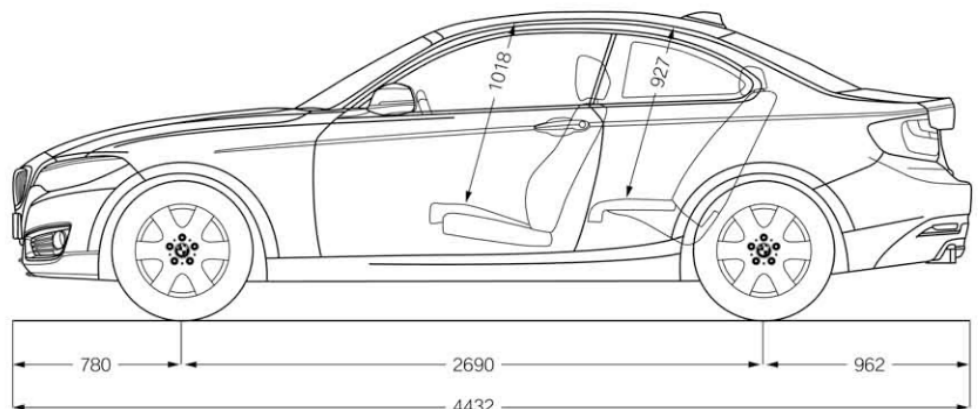

BMW Canada Inc. 2013 Product Planning Bulletin



M Performance Automobiles, “MPA”

In 2012, BMW launched a completely new category of vehicle to slot between the base Series products and BMW M, which competes more aggressively with the popular Audi “S” models. The first 3 M Performance Automobiles were high performance diesels that didn’t make it to North American shores (M550d, X5 M50d, X6 M50d). More recently, the 1 Series Hatchback launched in M Performance guise as the M135i in Europe, receiving rave reviews by the world’s top journalists. With the introduction of the 2 Series Coupé, Canada receives its first MPA in the form of the M235i Coupé, which replaces the former 135i Coupé. All early accounts suggest the M235i is a performance star! Cohesive, balanced, thrilling; it truly embodies The Ultimate Driving Experience.

There are 7 key components that differentiate an M Performance Automobile from base Series products:

1. Refined sports suspension, re-engineered through the expertise of BMW M.
2. Signature wheel design.
3. Improved steering.
4. Emotional exhaust note.
5. Differentiated exterior / interior details (including Ferric Grey Metallic contrasting side mirrors).
6. Improved components (e.g. M Sport brake).
7. Power improvements.

Below is competitive brand heirarchy showing M Performance Automobile’s position in the line-up:

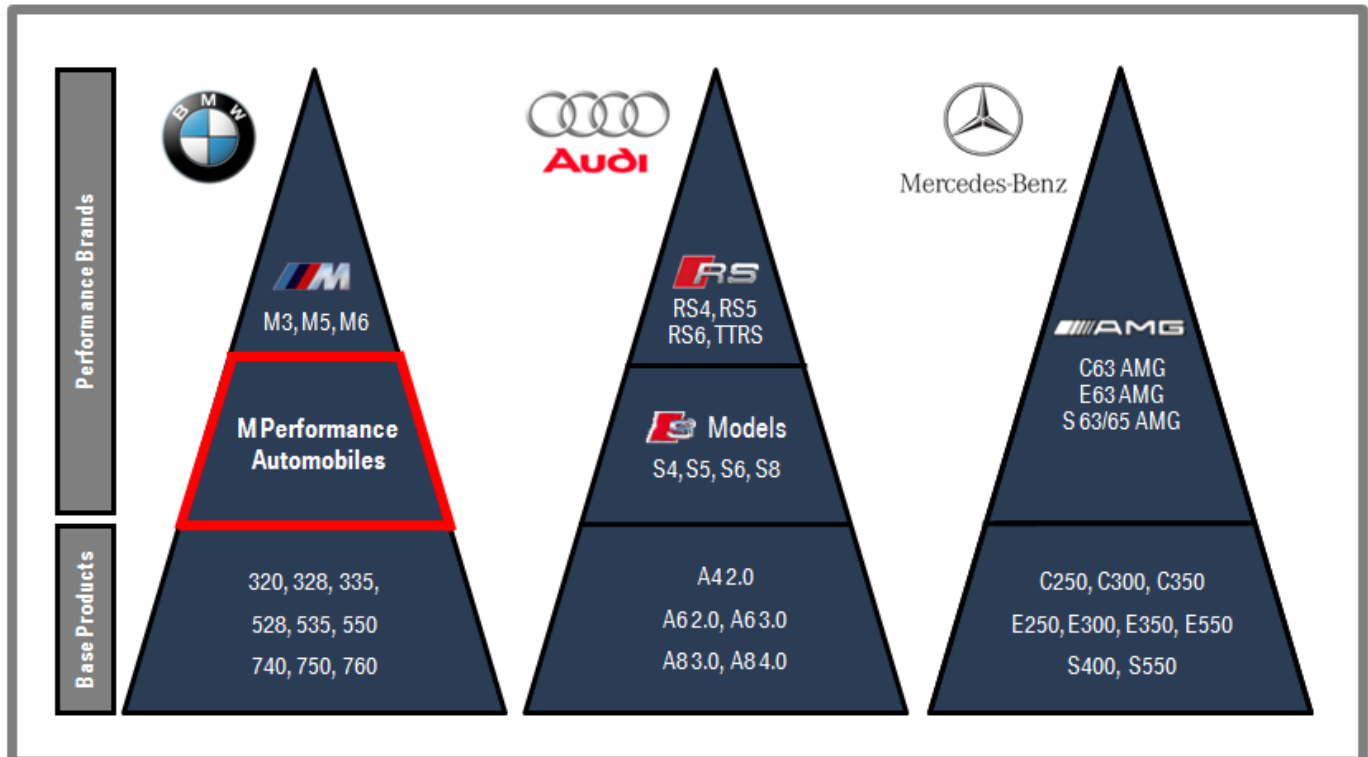

BMW Canada Inc.

2013 Product Planning Bulletin



New Features:

xDrive

Perhaps the most significant change with the new 2 Series Coupé will come in August/2014 when this platform is offered with xDrive All-wheel Drive. Both the 228 and M235 models will have xDrive variants beginning July production, greatly expanding the customer base and desirability of this product.



iDrive 4.2 with Touch Pad

BMW's iDrive interface saw significant enhancements for model year 2014 with the introduction of the new generation "iDrive 4.2". The new 2 Series Coupé will launch with this new system which offers a much improved user experience in the areas of navigation, Advanced Real Time Traffic Information, connectivity, entertainment, online access and voice commands.



BMW Lines

As with recent product launches including the 3 Series, 4 Series and 5 Series, "BMW Lines" will now be offered on the new 2 Series Coupé. For Canada, we have made "Sport Line" standard equipment on the 228 and "M Sport Line" optional at \$2,000 retail.

The M235i comes standard with M Sport, no other Lines are available.



BMW Canada Inc.

2013 Product Planning Bulletin



Transmission

A new 6-speed manual transmission will be standard equipment on both the 228i and M235i. The transmission has been borrowed from the upcoming M3/M4 and offers shorter throws and more precise shifting than the outgoing 1 Series 6-speed transmission. BMW's 8-speed Sport Automatic Transmission including paddle shifters and Launch Control will be optional for \$1,600 retail. No manual will be offered on either xDrive variant.

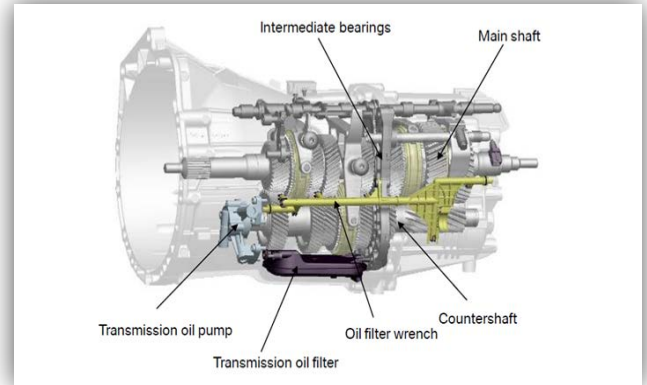

Power/Performance

The new 2 Series Coupé significantly raises the bar in both power and performance vs. the outgoing 1 Series.

228i vs. 128i:

i-6 cylinder replaced by twin-scroll turbo i-4 (N20).
241hp (+11)
258 lb-ft torque (+58)

M235i vs. 135i:

The current i-6, twin-scroll turbo engine (N55) optimized for additional power.
322hp (+22)
332 lb-ft torque (+32)



	128i	228i	A3 Sedan	CLA250
0 – 100km/h	6.4 sec	5.7 sec	6.4 sec (EST)	6.7 sec

	135i	M235i	S3 Sedan	CLA45
0 – 100km/h	5.4 sec	4.8 sec (EU)	4.9 sec	4.6 sec

BMW Canada Inc.

2013 Product Planning Bulletin



228 Coupé Model Overview:

MSRP 228i: **\$36,000** (+\$0)
MSRP 228i xDrive: **\$39,750** (new variant)

The 228i and 228i xDrive now come standard with Sport Line trim, which includes:

- Sport seats.
- Unique bi-colour 18" Light-alloy wheels (previously 17" std on 128i).
- Anthracite Roofliner.
- High-gloss Shadowline.
- New black Sensatec upholstery with red contrast stitching.



M228i with Sport Line, Black Sapphire Metallic.



Unique Sport Line front inlets and trim including fog lights



Standard 18" Sport Line Wheels Style 384

BMW Canada Inc.

2013 Product Planning Bulletin



The 228i adds a number of new standard features vs. the outgoing 128i including:

- 302 Alarm System
- 431 Anti-dazzle Interior Rear-view Mirror
- 465 Through Load System
- 563 Lights package

Total additional value vs. 128i:

\$3,000

Package structure vs. outgoing 128 has been heavily revised to improve simplicity, make key features more accessible and better align with the rest of the line-up. Premium Package will adopt a new structure and will now be offered in two variations:

“Premium Package Essential”, \$2,000 – targeting entry level buyers looking for core features who require lowest possible payments:

- 248 Steering-wheel heating
- 403 Glass roof, electrical
- 459 Seat adjustment, electric, with memory

“Premium Package Enhanced”, \$3,650 – this package offers many of the “must-have” options on the luxury buyers check-list including rear-view camera and navigation. It has been heavily discounted to be competitive in market. **We strongly recommend including this package in the majority of dealer orders from launch.**

- 248 Steering-wheel heating
- 3AG Rear view camera
- 403 Glass roof, electrical
- 430 Interior and exterior mirrors with auto anti-dazzle
- 459 Seat adjustment, electric, with memory
- 507 Park Distance Control (PDC)
- 609 Navigation system Professional
- 6WA Instrument cluster with extended contents

BMW Canada Inc. 2013 Product Planning Bulletin



In combination with M Sport Line, the 228 Coupé will offer a variation of the **M Performance Package**, featuring 3 high-value performance upgrades for only **\$1,500**, including:

- **M Sport Brakes** – painted blue calipers feature larger rotors, fixed 4-piston front calipers (from 2) on the front, and fixed 2-piston on the rear.
- **Variable Sport Steering** – by reducing the steering angles by 25%, this feature adds more precision to steering inputs while improving steering feel. Automotive journalists are unanimous; Variable Sport Steering is a valuable improvement to handling and cornering.
- **M Rear Spoiler** – improving vehicle downforce while enhancing the appearance of the vehicle.



18" M wheel style 461M with M Sport Brakes



228i with optional M Sport Line in Estoril Blue Metallic.

Please see product ordering guide for complete packages and options.

BMW Canada Inc.

2013 Product Planning Bulletin



M235i Coupé Model Overview:

MSRP M235i: **\$45,000** (+\$1,800)
MSRP M235i xDrive: **\$48,750** (new variant)

The new M235i offers a significant number of design and performance enhancements vs. the outgoing 135i that will make it highly attractive to consumers. The \$1,800 price increase is very modest in the context of all the added value on this vehicle. For example, M Sport Package on the outgoing 135i had a 92% national take-rate at \$2,100 retail, now standard equipment on the M235i. The entire list of new standard features on the M235 includes:

- 248 Steering-wheel heating.
- 337 M Sport Line
- 431 Rear-view mirror with auto anti-dazzle.
- 459 Seat adjustment, electric, with memory.
- 481 Sport seats, driver/passenger.
- 5DC Rear-seat headrests, folding.
- 6WA Extended instrument display.
- 710 M Leather steering wheel.
- 715 M Aerodynamics package.
- 760 Individual high-gloss Shadow Line.
- 775 Individual headliner anthracite.
- LC Dakota Leather upholstery.



M235i in Melbourne Red Metallic

As part of the new M Performance sub-brand, the M235i receives a number of new standard performance features that add significant value and appeal:

- 2NH M Sport brake.
- 2VF Adaptive M suspension (uniquely engineered for the M235i and with a further 10mm reduction in ride height vs. 228i with 2VF).
- 2VL Variable sport steering.
- 754 M Rear Spoiler.

Total additional value vs. 135i:

\$6,500



BMW Canada Inc.

2013 Product Planning Bulletin



Signature Contrast side mirrors in Ferric Grey Metallic



Unique M235i designation on entry sills



Signature M Performance wheels style 436M with M Sport Brakes and M badging on front $\frac{3}{4}$ panel.



M235i rear designation and M Rear Spoiler

Please see product ordering guide for complete packages.